

Wideband Systems, Inc.

www.wideband-sys.com

Advanced Signal Recording Products

DRS3100E

Digital Recording System

100+ Mbytes/sec

Key Features

- Sustained 100+ Mbytes/sec (800 Mbps) record and playback rates
- Configurable performance: record rate and record length
- Supports various interfaces and formats: LVDS, ECL/PECL, TTL, Serial FPDP, Telecom (PDH & SDH), PCM, 1553, Analog, Video and custom interfaces
- 3U Rackmount; Removable Disk Bank
- Local & remote control (opt. Ethernet)

Applications

- Real-time signal recording and playback: telemetry, sonar, radar, video, imagery, comms, SIGINT, ELINT, COMINT...

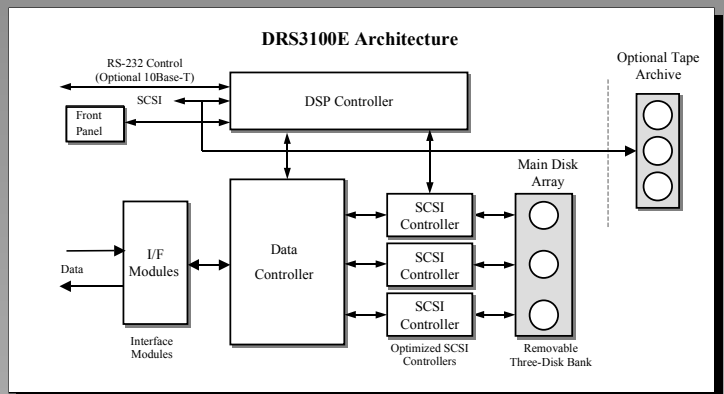

Wideband Systems, Inc. presents a significant new product providing wide bandwidth real-time signal recording and playback. The DRS3100E is a flexible digital recording system employing high reliability hard drives and uniquely optimized controller electronics. The product offers configurable performance and interface options to support a wide range of customer requirements (analog and digital).

The standard configuration of the DRS3100E supports continuous recording of data at 100 Mbytes/sec for 36 minutes (72GB disks). Reducing the data rate extends the record time by a proportional amount. Longer recording time can be provided by configuring the unit with larger disks (144GB or 300GB).

The recording media for the DRS3100E is a three-disk removable canister (disk bank) which facilitates the secure handling of the recorded data and enables back-to-back mission support. The DRS3100E not only satisfies field and laboratory recording requirements but also can provide significant support for the analysis of signals during playback.

The DRS3100E supports the off-loading of data to external tape drives (archive and restore) and supports the direct transfer of data to/from a PC workstation. The recorder is controlled by a user-friendly front panel interface and remotely by an RS232 interface. Network control is optionally provided.

Wideband Systems, Inc. designs and manufactures sophisticated recording instruments for the aerospace, communications, and intelligence industries. In addition to our off-the-shelf products we offer design services and extensive customization to meet your demanding applications. We look forward to an opportunity to serve you.



Wideband Systems, Inc.

www.wideband-sys.com

Advanced Signal Recording Products

DRS3100E

Digital Recording System

100+ Mbytes/sec

Specifications

- Dimensions: 5.25 x 19 x 23 inches
- Weight: 38 lbs.
- Temperature (op): 5 to 50 degs. C
- Humidity (op): 10% to 90%
- Temperature (non-op): -25 to 65 degs. C
- Humidity (non-op): 5% to 95%, non-cond.
- Power (VAC): 90-132/180-264 VAC
- Power (Hz.): 47 to 63 Hz.
- Power (Watts): <225 Watts

- Hard Disks (qty) Three
- Hard Disks (size) 72, 144 or 300 Gigabytes
- Hard Disks (speed) 10K RPM

- Operator Interfaces Front Panel (see below)
RS-232
10BaseT (optional)
- Data Transfer Tape Archive/Restore
Host SCSI Port
Removable Disk Bank

- Limited Warranty One Year

Interface Options

- Analog Input/Output (1 Ch, 8-12 Bits, 100 MHz)
- Analog Input/Output (2 Chs, 8-14 Bits, 50 MHz)
- Analog Input/Output (4 Chs, 8 Bits, 50 MHz)
- Digital Input/Output (8/16/32 Bits ECL/PECL)
- Digital Input/Output (8/16/32 Bits LVDS)
- Digital Input/Output (8/16/32 Bits TTL)
- Mil-Std-1553 (multi-channel)
- Telemetry (0 to 40 Mbps PCM and Analog)
- Telecom (PDH, SDH, SONET)
- Parallel and Serial FPDP (FibreXtreme)
- DCRSi, DIR, Video, and more.....

- Custom Interfaces are available

Ordering Information

- Please contact our technical sales staff to configure your Digital Recording System. Each system can be tailored to meet your interface, control, and fault tolerance requirements.

Email: sales@wideband-sys.com

